

LONGITUDINAL SECTION THROUGH TANK

SECTION A-A

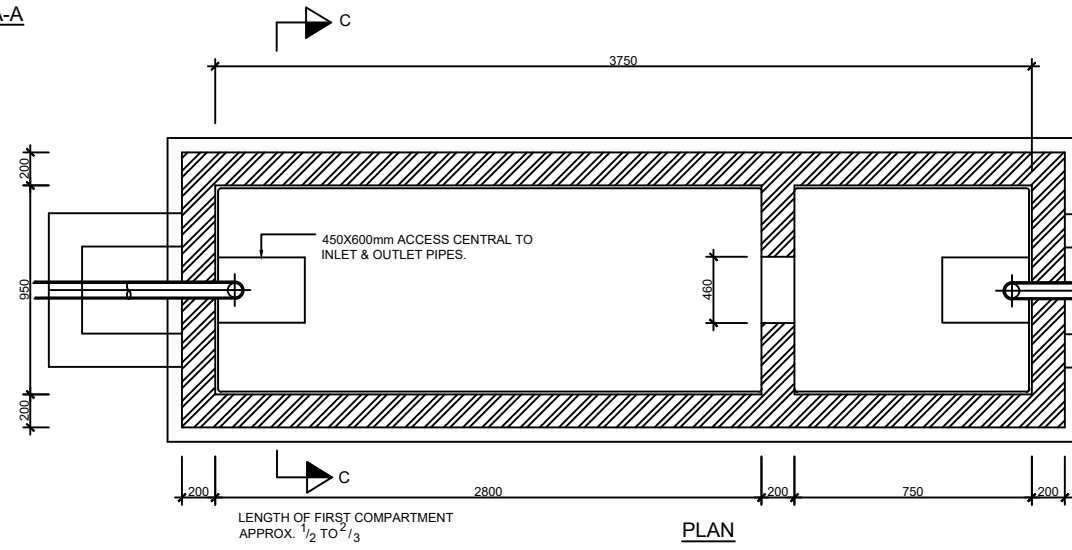

DISTRIBUTION CHAMBER

DISPOSAL TRENCH/ SOAK PIT DESIGN

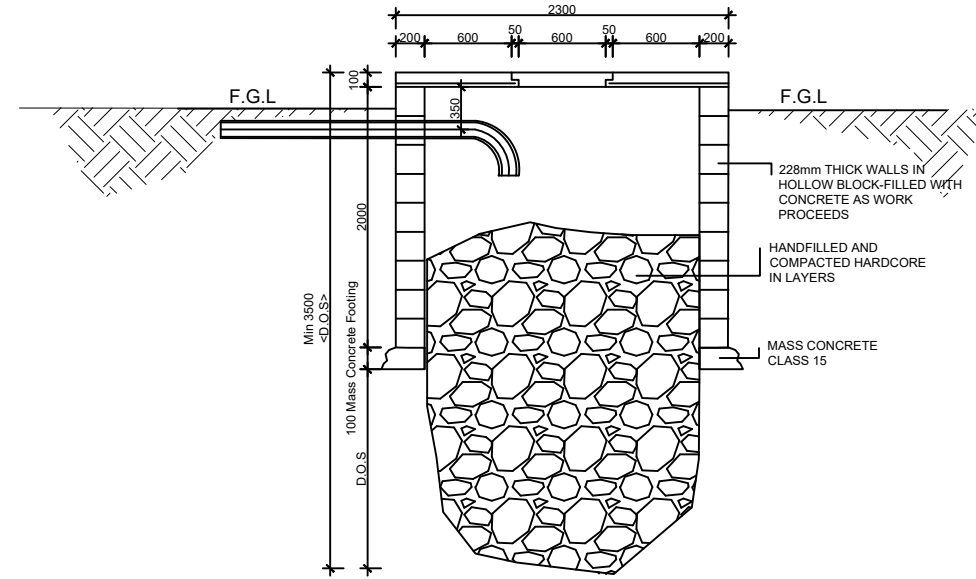
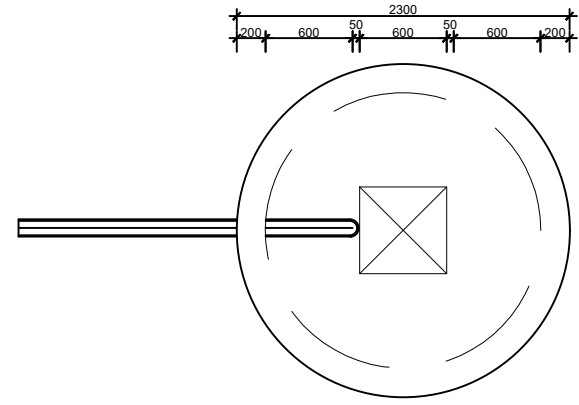
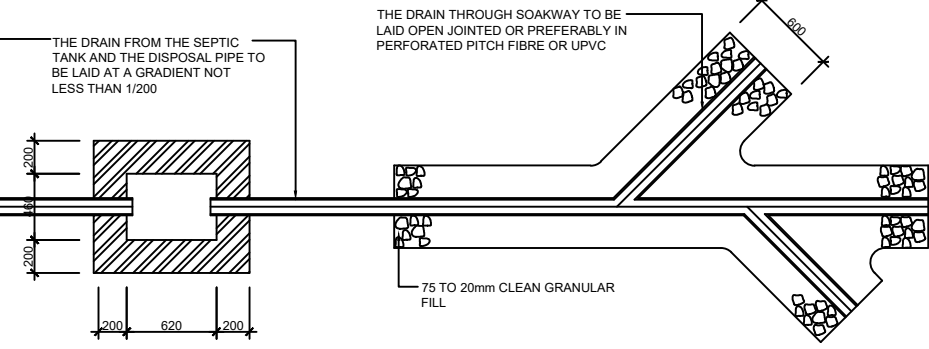

SEPTIC TANK CHAMBER DETAILS